

**Substrate
Volume
Cutting**

Fletcher ALTA⁹⁹ Multi-Material Volume Cutter

Consistent Cutting Speed
Provides Reliable Edge Quality

Eliminate Fatigue & Increase
Production Output &
Multi-Tasking Functions

Cuts Clean &
Debris-Free Eliminating
Secondary Processes

**Aluminum
Sheets**
Up to .080"

**Aluminum
Composites**
Up to 4mm

PVC
Up to 10mm

**Corrugated
Plastics**
Up to 1/2"(13mm)

Foamboard
Up to 1/2"(13mm)



Accurate. Versatile. Durable. Profitable. Proven.

Since 1868, Fletcher-Terry has revolutionized advanced cutting solutions for numerous global industries. Our versatile ALTA99 multi-material Cutter is geared towards volume cutting where production output is required with a full range of rigid substrates either with a pre-printed or posted printed graphic application. The ALTA99 cuts aluminum composite and aluminum sheet materials, debris-free, enabling you to place it in the same work area as your dust-sensitive printing device.



Ask your distributor about our new Substrate Swatch Book to assist you in your cutting needs.



The Fletcher-Terry Company, LLC

www.fletcher-terry.com



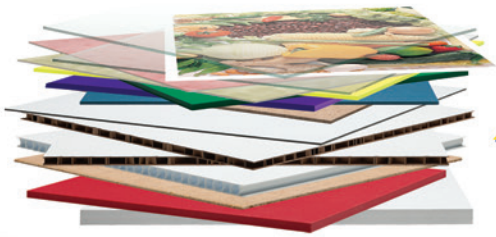

ALTA⁹⁹

FLETCHER Automated Substrate Cutter

www.fletcher-terry.com

SIGN FABRICATORS • DIGITAL PRINT AND PHOTO LABS • PHOTOGRAPHERS • MATERIAL CONVERTING SUPPLIERS • POP DISPLAY/EXHIBIT HOUSES • SIGN

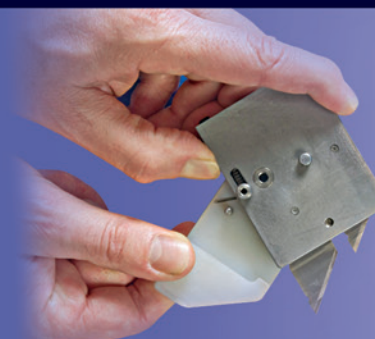

Interchangeable
Cutting Heads

**“Double Blade”
Knife Cutter**
Corrugated Plastics
Foamboard Up to 1/2”(13mm)
PVC Up to 10mm



**Aluminum
Sheets**
Up to .080”



**Aluminum Composites
(AMC)**
Up to 4mm



Substrate Volume Cutter

ALTA99 Technical Specs

Vertical Cutting Capacity: 99” (2.5m)

Production Aid: Four different starting height locations depending on size of the material – 24” (.61m), 48” (1.22m), 72” (1.83m) and 99” (2.51m)

Cutter Head: Fixed travel speed to starting location: 9.7 inches per second

Interchangeable Heads: Cutters, wheels and tool holders made from steel

Drive Mechanism: The power behind the Alta99 is its motor-driven lead screw drive mechanism with variable speed control powered by a 1/2 Hp Motor.

Unique Performance Features

- Interchangeable Cutting Head Technology
- Cut’s clean debris-free, no secondary processing
- Can be placed in same room as printer, saving valuable shop floor space
- Equipped with laser sight line for accurate cutting – comes as part of purchase package
- Mounts on wall or free-standing
- Heavy duty design for years of dependable service

Part No Information-ALTA99

Part # 04-800: Domestic Unit

Part # 04-801: CE International Unit

Purchase Package

- (1) Alta99 Unit (free-standing or wall-mount setup)
- (1) “Double Blade” Knife Holder
- (1) ACM Wheel Holder
- (1) Aluminum Sheet Wheel Holder
- (1) Laser Sight Cutting Guide
- (4) Tubes of 10 Knife Blades
- (2) Production Stops

Options & Replacement Accessories

- 05-222** Blades (10/tube) used with Double Blade Holder
- 05-230** Aluminum Composite Wheels (2/envelope)
- 17-416** Aluminum Sheet Holder for 05-231 Wheels
- 05-231** Alum Sheet Wheels (2/envelope) for .063 & .080 Aluminum
- 05-232** Alum Sheet Wheels (2/envelope) for .040 Aluminum
- 17-419** Single Thin Blade Holder
- 05-004** Utility Blade Holder for 17-419

Cuts
4' x 8'
Sheets



Mutoh ValueJet 1608HS Hybrid Printer

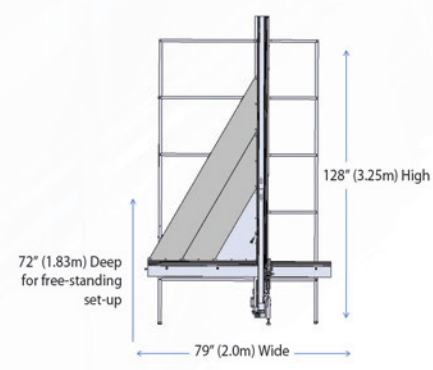

Alta99 Market Users

- Sign & Graphic
- Picture Framing
- Architectural
- Building & Construction
- Government Agencies
- Digital Printers



The Fletcher-Terry Company, LLC